

VVER-1000 SFAT

Final Report on Task FIN A 1073 of the Finnish Support Programme to the IAEA Safeguards

A. Tiitta (VTT), M. Tarvainen (STUK),
S. Iievlev, A. Dvoeglazov (State Technical and Scientific Centre
for the Nuclear and Radiation Safety, Ukraine),
V. Bytchkov, D. Popescu, Y-G Lee, M. Hosoya, V. Goulo (IAEA)

In STUK this study was supervised by Matti Tarvainen

The conclusions presented in the STUK report series are those of the authors and do not necessarily represent the official position of STUK

ISBN 951-712-596-8 (print)

ISBN 951-712-597-6 (pdf)

ISSN 0785-9325

Dark Oy, Vantaa/Finland 2002

TIITTA Antero (VTT), TARVAINEN Matti (STUK), IIEVLEV Serhii, DVOEGLAZOV Alexander (State Technical and Scientific Centre for the Nuclear and Radiation Safety, Kyiv, Ukraine), BYTCHKOV Valerij, POPESCU Dorel, LEE Young-Gil, HOSOYA Michio, GOULO Valery (IAEA). VVER-1000 SFAT. Final Report on Task FIN A 1073 of the Finnish Support Programme to the IAEA Safeguards. STUK-YTO-TR 192. Helsinki 2002. 22 pp.

Keywords: safeguards, verification, NDA, VVER-1000, spent fuel, SFAT device

Abstract

IAEA needed a rugged spent fuel attribute tester, SFAT, for verifying spent fuel assemblies of the Ukrainian VVER-1000 reactors in line with IAEA safeguards measurement standards and criteria of verification.

Spent fuel verification using the existing Improved Cerenkov Viewing Device is becoming more and more difficult and sometimes impossible primarily due to the increasing cooling time of low burnup assemblies and damaged fuel in closed bottles. Other complicating factors include dummy assemblies in the ponds, different storage configurations, difficult access and variation in the quality of the pond water.

The task to develop a SFAT device for the eleven Ukrainian VVER-1000 facilities has been accomplished under the Finnish Support Programme (FINSP) to the IAEA safeguards under the Task FIN A 1073. The task made use of the experience gained on designing and implementing SFAT devices in Finland.

Based on the agreed user requirements, a series of measurement campaigns were jointly organized by the IAEA Safeguards Department, Ukrainian Nuclear Power Plant Operators and the FINSP first at the Zaporozhye and Khmel'nitski NPPs and finally in 2001 at the Rovno and South Ukraine NPPs.

Several hardware configurations were tested to take into account the measurement conditions including pond lattice geometry, fuel storage conditions, high background radiation and the design of the upper part of the VVER-1000 fuel assembly. The best results were achieved using a large CZT detector, an optimized collimation and precise positioning using the refuelling machine. The system is now ready for routine inspection use at nine of the eleven Ukrainian VVER-1000 units.

During the development of this verification method, special attention was paid to minimizing intrusiveness and maximizing efficiency of the procedure while ensuring compliance with national and facility level safety regulations in Ukraine.

Contents

ABSTRACT	3
1 INTRODUCTION	5
2 PRINCIPLE OF OPERATION OF SFAT	6
3 GENERAL INFORMATION ON VVER-1000	7
3.1 VVER-1000 assemblies	7
3.2 Interim spent fuel storage	8
3.3 Cooling pond water	8
4 USER REQUIREMENTS	10
4.1 Intended application	10
4.2 Required performance	10
4.3 Facility details and installation requirements for any facility specific applications	10
4.4 Operating requirements	10
4.5 Reliability and maintenance	11
4.6 Data acquisition and processing	11
4.7 Authentication	11
4.8 Calibration	11
4.9 Documentation	11
5 SFAT APPROACHES FOR VVER-1000	12
5.1 IAEA SFAT design and operation	12
5.2 FINSF approach	12
6 REVIEW OF MEASUREMENT CAMPAIGNS	14
6.1 Early measurement campaigns	14
6.2 Campaign at Zaporozhye NPP in 2000	15
6.3 Campaign at Rovno NPP in 2001	16
6.4 Campaign at South Ukrainian NPP in 2001	16
7 SUMMARY	20
ACKNOWLEDGEMENTS	21
REFERENCES	22

1 Introduction

The International Atomic Energy Agency (IAEA) verifies spent fuel for safeguards purposes. Usually the verification of the fuel assemblies stored in storage ponds is performed using an Improved Cerenkov Viewing Device (ICVD). In cases where the verification by ICVD turns out to be difficult or even fails, a complementary method is the Spent Fuel Attribute Tester (SFAT) [1]. The rationale behind this task was that there was no SFAT device available, which could perform the verification at the VVER-1000 facilities in those cases where the ICVD would fail.

A great number of the VVER-1000 reactors are in operation in Eastern Europe, most of them in Ukraine. The principal verification problem with those units is connected to the shielded assembly design and sometimes a poor water quality as regards contamination and transparency making both ICVD and SFAT type verification difficult.

The storage capacity of the VVER-1000 fuel ponds is very limited, and the fuel has to be transferred away from the reactor after a few years of cooling. At present a dry storage facility is in operation at the Zaporozhye NPP and under construction or projected at other NPPs. This means that the spent fuel inventories at the reactor storage ponds consist principally of relatively short-cooled fuel. However, there are also older

fuel assemblies in the storage ponds and they are getting difficult to verify by the ICVD. The limited storage space in the fuel storage ponds of the reactors makes it necessary to store the long-cooled assemblies as intermixed with recently evacuated high burnup assemblies. Adjacent recently evacuated assemblies induce a high background of scattered radiation at the detector position thus cumbering the detection of characteristic peaks of long-cooled assemblies under verification.

Another problem are the closed bottles in the storage ponds intended for storage of leaking fuel assemblies. A bottle may be declared as containing a fuel assembly or declared as empty. In both cases a clear verification is needed. If this problem cannot be solved using a SFAT device other devices e.g. IRAT could be used, instead.

The goal of this task was to design and construct a prototype SFAT device suitable for the VVER-1000 facilities in Ukraine. This report concludes the results obtained. Starting from the end user's requirements [2], the final design has been developed through consecutive design and test measurements. The final design presented combines the virtues of the IAEA standard SFAT with the new results received during this task. Description of the evolution of the task can be found in the previous interim reports [2–5].

2 Principle of operation of SFAT

A SFAT device is used to verify the spent fuel assemblies in the intermediate spent fuel storages. It should be able to distinguish a spent fuel assembly from any other radiating artefact, e.g. irradiated dummy assembly, stored in the storage pond, but not containing irradiated nuclear fuel. This level of verification is called gross defect. The fuel assemblies are not moved or touched during the measurement. Instead, the instrument is moved and positioned above each assembly to be verified. Normally the assemblies are stored in a tight array in the storage pond preventing the access from aside and allowing only the measurement of the radiation emanating upwards.

The SFAT device consists of a gamma detector, a radiation shielding and an air-filled collimator pipe enclosed in a watertight housing. The device is submerged into the pond water and the detector views through its collimator pipe characteristic radiation of fission products emitted from the spent fuel assembly located right beneath the

SFAT device. Directly in front of the detector there may be an additional collimator and radiation shield made of heavy material e.g. lead or tungsten.

The radiation is measured using an energy-dispersive detection system, usually a multi-channel pulse-height analyser. Energy dispersion allows for detecting radiation specific to fission products, thus indicating that the target contains fissile material and fission products produced by irradiation in a nuclear reactor. In order to detect efficiently radiation directly emanated from the spent nuclear fuel region of the assembly under verification, the collimation of the device must be properly devised. Concurrently care must be taken that the device would not see the full-energy radiation emanating from the adjacent assemblies. The principal target radiation to indicate the presence of irradiated nuclear material is the 662 keV gamma peak of ^{137}Cs .

3 General information on VVER-1000

3.1 VVER-1000 assemblies

The fuel assemblies have a hexagonal cross section and they are stored in a hexagonal lattice in the fuel pond. The structure of the top of a fuel assembly is displayed in Figure 1. The active length of a fuel rod is 3530 mm. In the rods, above

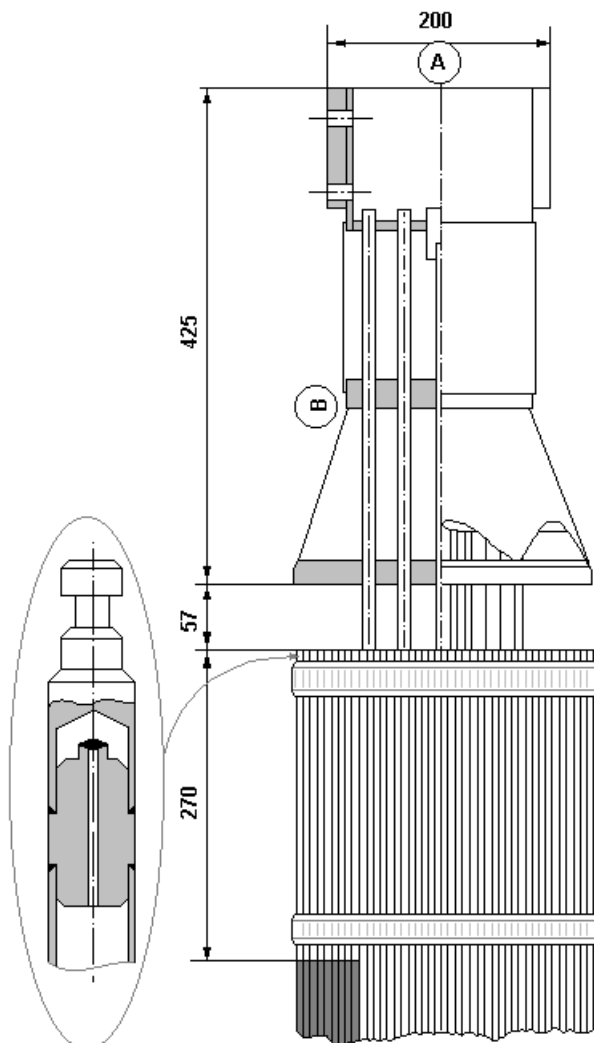

Figure 1. Structure of the top of a VVER-1000 fuel assembly.

the fuel pellets there is a zirconium plug of 50 mm in length. The top of the fuel assembly is about 750 mm above the top of the active zone. The top of the fuel assembly is a cylindrical tube with the outer diameter about 175 mm. Inside the cylinder there is space for the control rod assembly, which is inserted in the control rod channels of the fuel assembly through this cylinder. The irradiated control rod assemblies are stored in the fuel assemblies. The top part of the fuel assembly serves also as the handle for the attachment of the fuel assembly to the refuelling machine. The supporting elements of the handle are two claws on the opposite sides of the outside top of the cylinder. These claws attach to the refuelling machine. The cylindrical top part continues with a conical shoulder at about 275 mm below the top of the assembly. The shoulder prevents the access closer to the fuel. The tip of the SFAT collimator tube cannot approach closer than about 480 mm above the top of the fuel pellets.

As for radiation source an irradiated assembly consists of two main zones. The first zone, which is closest to the detector, is the irradiated stainless steel head, radiating mainly gamma rays of ^{60}Co . The second zone is the fuel containing fission fragments, with ^{137}Cs as the principal gamma emitter, starting about half a metre lower. High-energy gamma radiation from the head produces a strong background of multiply scattered gamma rays, which may hide the relatively weak target signal of lower energy. Below the shoulder of the assembly, indicated as B in Figure 1, is the place where the fuel is least shielded from the SFAT instrument. The target area for positioning the SFAT device is shown in Figure 2.

3.2 Interim spent fuel storage

Figure 3 presents the pond structure of the Zaporozhye NPP units. The spent fuel is stored in two interim storage ponds of the reactor hall, TG21B01 and TG21B03 in Figure 3. Adjacent to the storage ponds there are two smaller ponds, a maintenance pond, TG21B02, which is used for fuel storage too, and a universal socket.

The fuel is stored in the racks with a hexagonal lattice configuration. There are racks for normal and tight storage. For normal storage the lattice pitch is 400 mm between the centres of the assemblies and the gap between assemblies is about 130 mm. For tight storage the pitch is about 320 mm and the gap 40 mm, see Figure 4. The leaking assemblies are closed individually in hermetic bottles, which are stored in large ponds.

There are simultaneously high burnup (BU) assemblies with the cooling time (CT) equal to 0–5

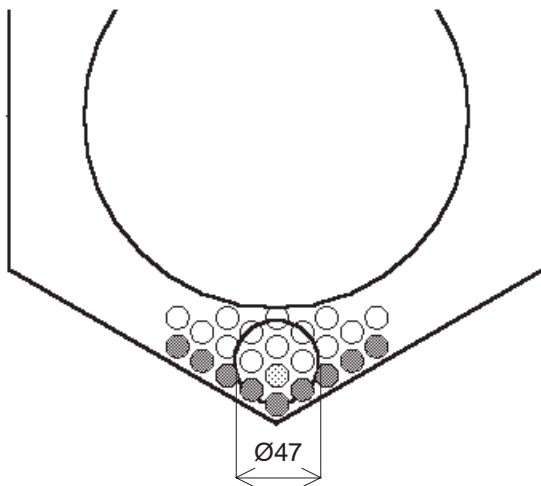

Figure 2. The target area available for detection of fission-product isotopes in a VVER-1000 assembly. The small circles indicate individual fuel rods.

years and assemblies with low burnup and long cooling time in the ponds. Leaking assemblies are stored in the interim storage ponds for the time being. Accordingly they may have considerably long cooling times.

In a conservative approach one should be able to verify a low burnup and long cooling time assembly surrounded by high burnup and short cooling time ones in tight storage conditions.

3.3 Cooling pond water

The water may be contaminated by chemical and radioactive impurities. Contamination makes the verification of assemblies by ICVD in some cases rather problematic during high water level.

Radioactive contamination could lead to the situation that an improperly shielded detector unit would register ^{137}Cs radiation in an empty position of the pond and the signal might be comparable to that of a real low burnup and long cooling time assembly.

The maximum cooling pond water contamination level ever registered at the Zaporozhye NPP is approximately 4 MBq/l. The principal contaminants are ^{137}Cs and ^{134}Cs . Usually the contamination level during the verification campaigns does not exceed one tenth of this maximum. Such a strong possible background level poses additional demands to the detector shielding and measurement geometry. Gamma radiation should not penetrate the detector from directions other than from the assembly under verification.

The device shielding, measurement geometry and positioning system must comply with the demands derived from the high background level, from the structure of the assemblies and from the storage geometry.

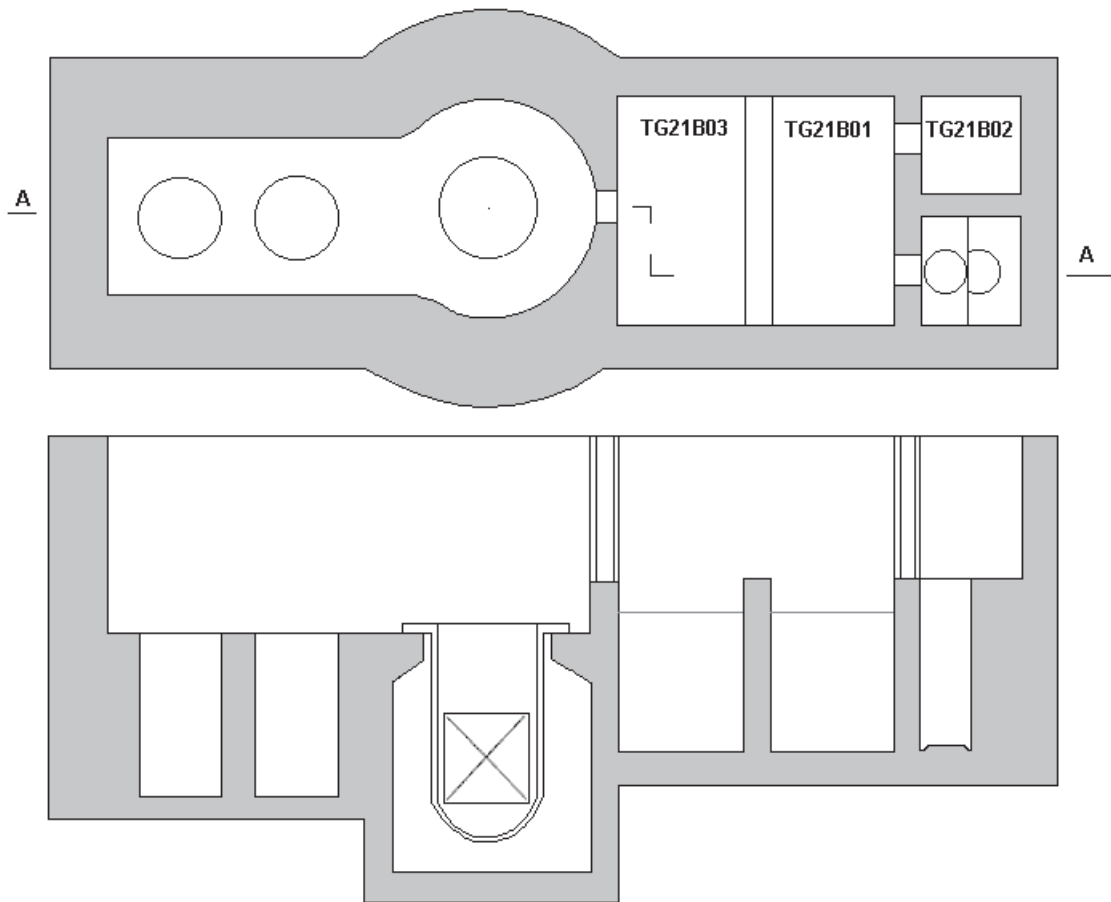

Figure 3. The arrangement of the reactor and the fuel storage ponds at ZNPP units.

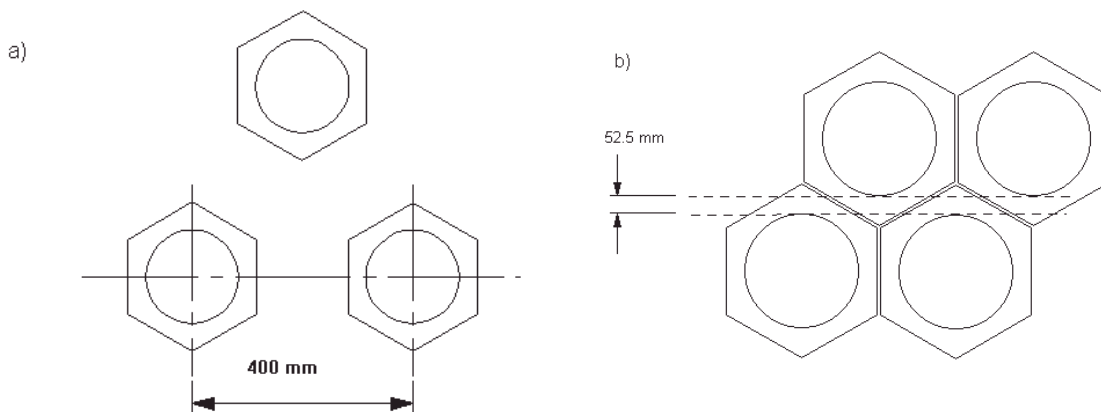

Figure 4. Two arrangements of assemblies in the VVER-1000 storage ponds. a) Normal storage lattice. b) Tight storage lattice.

4 User requirements

4.1 Intended application

The SFAT should serve as a verification instrument for spent fuel stored in ponds at VVER-1000 facilities for

- 1) long cooling time items;
- 2) low burnup items;
- 3) fuel in closed containers/bottles.

The problem of spent fuel items stored in closed containers or bottles should also be considered as a target.

Before routine use may start, the SFAT must pass the acceptance tests for a routine use instrument. This includes meeting the system technical and safety specifications and undergoing a formal usability test or its equivalent in terms of field exercises.

The SFAT would be the instrument of choice for inspection gamma measurement applications requiring transportability, ease of use and durability. This would include attribute measurements for fission products contained in spent fuel assemblies designed for VVER-1000 reactors. The system should be able to distinguish between fuel and non-fuel items, also in the presence of contaminated water.

4.2 Required performance

By positioning the SFAT above the fuel assemblies, above other similar items or above containers in VVER-1000 spent fuel ponds, the system should be capable of

- 1) identifying, in situ, spent fuel through low or medium resolution gamma spectrometry;
- 2) determining the spent fuel presence in individual fuel assemblies in the spent-fuel pond;
- 3) determining the spent fuel presence in closed containers or bottles, in this case another verification geometry may be accepted;
- 4) provide yes/no answer in-situ for each meas-

urement, regardless the condition of water contamination in the pond.

The system shall be designed in such a way that

- 1) it has optimum size and weight and is acceptable to the operator;
- 2) it is rugged, capable of transport with a special transport container, which should be provided;
- 3) it allows for simple installation into the refueling machine or other operator accepted equipment, fast turn on and it is easy to make it available for operation;
- 4) it has diagnosis capabilities and indication of operational problems;
- 5) is waterproof and can be stored under water when not in use;
- 6) is easy to be decontaminated on site.

4.3 Facility details and installation requirements for any facility specific applications

The technical specifications of VVER-1000 SFAT should be in line with the State (Ukraine) and facility safety regulations. The conditions are described in documents issued by Ukrainian Authorities and nuclear facilities in Ukraine, where such an instrument is to be used.

The system should be useable in conditions of the environment typical to these facilities including power supply, radiological and safety hazard matters.

4.4 Operating requirements

The measurement electronics will need to operate for up to 8 hours on back-up batteries if AC is not available and provide sufficient data storage for a typical inspection. The temperature and humidity range should equal the conditions specific to spent fuel pond areas of VVER-1000 facilities and be environment specific in VVER-1000 reactors.

4.5 Reliability and maintenance

The SFAT should be highly reliable with a mean time between failures (MTBF) of better than 3 years, depending on the frequency of usage. The SFAT should have modular design allowing simple and quick maintenance on the spot through modular replacement of the detector sensor package. A person responsible for maintaining the equipment should be established.

4.6 Data acquisition and processing

IAEA standard equipment should be used.

The system shall carry out the following functions:

- 1) Collect gamma-ray spectra and determine the energy and presence of prominent lines;
- 2) Determine the presence of spent fuel;
- 3) Convenient identification and storage of individual measurements;
- 4) Connectable to a computer for review or print out of measurements.

The necessary acquisition time should be minimised in order to reduce inspection time. The acceptable time for verification of one assembly has not been specified, but it can be assumed that about 5 minutes would be reasonable. For exceptional cases also a longer measurement time could be acceptable.

4.7 Authentication

SFAT shall be operated in an attended mode. No authentication is necessary. The system should satisfy Agency requirements with respect to

tamper indication—i.e. provisions to be kept under seal, etc.

4.8 Calibration

Upon completion of detailed tests of its performance characteristics, the system should be calibrated for various sensor modules (e.g. CdTe or NaI). The calibration should be done in such a way that the reproducibility should be achieved simply by turning on the system. The system calibration should be easily monitored.

4.9 Documentation

A paper master and electronic copies in Microsoft Word (or other acceptable text editor) of the following documents should be supplied to the Agency:

- 1) Functional Requirement Specification
- 2) Acceptance Test Plan
- 3) Design Specifications
- 4) Quality Assurance Plan (this is optional, but consideration should be given if the development warrants this document)
- 5) Safety Evaluation Documentation
- 6) An Operating Manual to the Agency format
- 7) Maintenance Manual
- 8) Software Documentation.

A short procedure sheet should also be foreseen. In addition, the system documentation shall be available for service and repair and for NPP operators. Training material for use at the Agency shall be available and training shall be given to inspectors.

5 SFAT approaches for VVER-1000

5.1 IAEA SFAT design and operation

A transportable SFAT device is readily available at the IAEA and authorized for use in gross-defect level verification of spent fuel storages. [6] The IAEA SFAT device is relatively lightweight, <20 kg, and can be equipped with collimator pipes of different lengths, up to 2500 mm. It is handled by a hand-winch to be attached in the handrails of the fuel-handling machine. Correct positioning above the target assembly is implemented using the fuel-handling machine. Vertical positioning, when above the target, is done using the winch.

Tests with VVER-1000 fuel have been made with the IAEA standard SFAT at the Kozlodui NPP in Bulgaria. A clear fission-product fingerprint was obtained in some of the cases (a certain burnup/cooling-time range), but the reliability of the verification and the verification for all cases specified in the user requirements could not be established. Complementary tests have been made at the Khmel'nitski and Rovno NPPs, but the optimum geometry could not be established. There were also problems in positioning the device above the target assembly and in verifying the correct positioning. Subsequently the Ukrainian Regulatory Authority has forbidden handling of such devices from the edge of the fuel pond due to safety risks. The only remaining alternative was to mount the SFAT device in the refuelling machine.

5.2 FINSP approach

The approach of the FINSP was

- to find an accurate and reproducible positioning system for the SFAT,
- to find an optimum measurement geometry and detector shielding,
- to test and find an optimal detector.

Good experience on the operation of the SFAT device using the fuel-handling machine at the intermediate storage of the Olkiluoto NPP in Finland [7] encouraged looking into possibilities to use the refuelling machine of the VVER-1000 facility for handling and positioning of the SFAT device. However, some basic differences both in the design of the fuel-handling machines and in their operation made the application of the VVER-1000 refuelling machine into this purpose nontrivial.

Although VVER-1000 facilities are very similar in construction, the fuel storage ponds and refuelling machines differ. Refuelling machine construction is one of the key issues in using the SFAT. Some main differences are described below.

The operative body of all VVER-1000 refuelling machines is the mast. The mast consists of 3 coaxial tubes for adjustment of the height. The outer tube is fixed in the machine body. The middle tube is an extension and the inner tube has the grapple for the assemblies. The refuelling machines of all Zaporozhye (ZNPP) units have equal construction. The middle tube is hanging on the inner tube and forms a mechanical shield for the assemblies to be transferred. It cannot be lifted independently. Opposite to the ZNPP, the middle tube of the South Ukraine NPP (SUNPP) refuelling machines can be lifted independently. As a consequence facility-specific attachment mechanisms had to be designed.

Operation of the refuelling machine is performed remotely in the machine control room and it is monitored through the digital position indicator and the underwater video system of the machine. The machine operator is not present in the reactor hall. The inspector in the reactor hall and the refuelling machine operator can communicate by telephone. This could require the presence of

two inspectors, one in the reactor hall for running the measurements and another in the machine control room to observe that the SFAT is correctly being positioned. This requirement was not attractive to the end user.

The approach selected for the optimization of the geometry is based on the relationship between the luminosity and the geometrical parameters of the measurement:

$$L \propto A_T \cdot \Omega_D = \frac{A_T \cdot A_D}{R^2}. \quad (1)$$

Here A_T denotes the target area seen by the detector on the level of the top of the fuel, and A_D denotes the area of the detector entrance window. R denotes the distance between the detector and the top of the fuel. This would call for maximizing the target area and the detector size and minimizing the distance. One can see in Figures 1 and 2 that the fuel design severely limits the available target area. In addition to maximizing the signal by maximizing the value of eq. (1), one must take into account the background emitting from the array of the fuel assemblies stored in the pond. In the first approximation this array represents an infinite-area surface source. The radiation at the detector position of this kind of source does not depend on the distance itself, only on the attenuating material between the source and the detec-

tor. As the attenuating power of lead or tungsten vastly overweighs that of water, it was decided that the geometry should be based on making the distance as short as practicable and taking care of the background shielding using heavy material, lead and tungsten, as appropriate, around and in front of detector. One factor affecting the optimum collimator design is that the entrance of the collimator pipe cannot be brought closer than about 480 mm from the upper level of the active zone of the fuel pins in the assembly. The structural material and water between the active zone of the fuel assembly and the collimator pipe entrance considerably attenuates the full-energy peak of the direct radiation making the detection of the ^{137}Cs photopeak a demanding task.

The detector should be chosen in such a way that it would provide the maximum signal-to-noise ratio for a certain measurement time. The most efficient detectors seem the most attractive, but there are also other parameters playing a role in this choice, e.g. availability, price, physical size, resolution etc. One must also consider detectors of mature technology, e.g. scintillation detectors, NaI or BGO, against modern detector types, where the technology is under active development, e.g. CdZnTe (CZT) detectors. In the latter case also the prospects and expectations of their development in the near future should be taken into account.

6 Review of measurement campaigns

6.1 Early measurement campaigns

The first measurements were taken in 1998 at the Zaporozhye NPP. [2] Based on those measurements it was established that the effect can be seen and high and medium burnup assemblies can be verified using a 1500 mm long collimator pipe of 30 mm inner diameter using either a 2×0.5" NaI or a 40×40 mm BGO detector. It was also found that the shielding used was not sufficient at high water contamination level with these detectors. Additionally, it was noticed that the operation of the SFAT device from the bridge of the refuelling machine involves risks attached to the remote operation of the refuelling machine. More accurate positioning was required.

For the next two of campaigns, which took place in 1999 at the Zaporozhye NPP [3, 4] a method to attach the SFAT device into the refuelling machine was devised and an approval to this arrangement was obtained both from the Ukrainian Authority and from the facility operator. The only possibility for attaching the SFAT in the refuelling machine was to use the middle tube. The vertical position was adjusted by lifting the inner tube from which the middle tube is hanging. The SFAT was attached to the middle tube using a special attachment ferrule, see Figure 5.

In these campaigns, a long (1.63 m) and a short (0.63 m) collimator pipe were tested using a 500 mm³ CZT detector and larger scintillation detectors (NaI and BGO). The best results were obtained using the CZT detector and short collimator pipe with additional lead cylinders in the pipe to shield against direct radiation from nearest

neighbours. The results of these campaigns were reported in ref. [3].

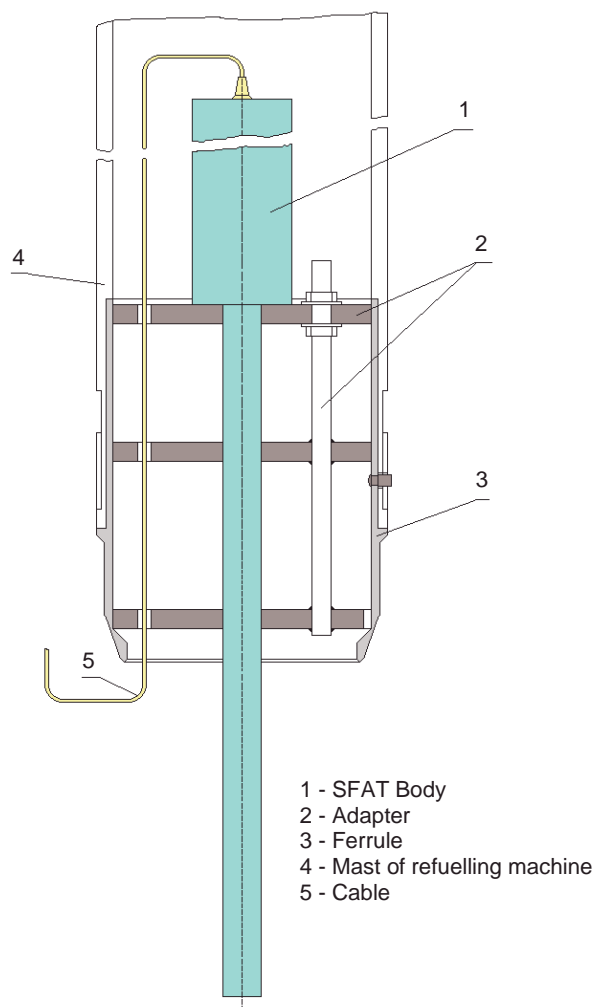

Figure 5. Schematic picture of a VVER-1000 SFAT device as installed into the refuelling machine of the ZNPP.

Table I. The assemblies measured at the ZNPP in 2000.

No	Assembly ID #	File name	Year of discharge	Burnup (GWd/t)	Live time (s)	Dead time (%)	Peak area	S/E	Verification (Y/N)
1	0342	0342	1988	31.67	300	1.0	1307	3.00	Y
2	0349	0349	1988	31.67	300	1.0	1509	5.00	Y
3	0354	0354-2	1988	31.67	300	1.0	1546	6.00	Y
4	0255	A0255	1986	12.65	300	1.3	483	2.30	Y
5	0256	A0256	1986	12.65	300	1.3	523	2.70	Y
6	0260	A0260-4	1986	12.65	600	1.2	681	2.00	Y
7	0227	A0227-3	1986	13.20	300	0.7	371	2.10	Y
8	0250	A0250	1986	13.20	300	1.3	399	1.50	Y
9	0406	A0406	1987	18.18	300	1.6	465	1.90	Y
10	0414	A0414	1987	18.18	300	2.0	435	1.80	Y
11	0462	A0462	1987	18.18	300	2.0	817	3.30	Y
12	0463	A0463	1987	18.67	300	1.3	841	3.70	Y
13	0469	A0469	1987	18.67	300	2.0	750	2.80	Y
14	N7269	7269-1	1998	17.43	300	6.8	2035	2.80	Y
15	ED5871	Bottle	1997	41.52	600	0.0	51	0.90	N

6.2 Campaign at Zaporozhyye NPP in 2000

A complementary campaign with the presence of an IAEA inspector was organised in 2000. In this campaign all assemblies were successfully verified except for an assembly closed in a hermetic bottle using the device shown in Figure 6. [4] Here a 300 mm extension was added in front of the short collimator pipe. The assemblies measured in this campaign are listed in Table I. Fifteen assemblies were measured during this campaign. The assembly #ED5871 was closed in the hermetic bottle. The peak analyses were made using the IAEA standard software (SfatW95).

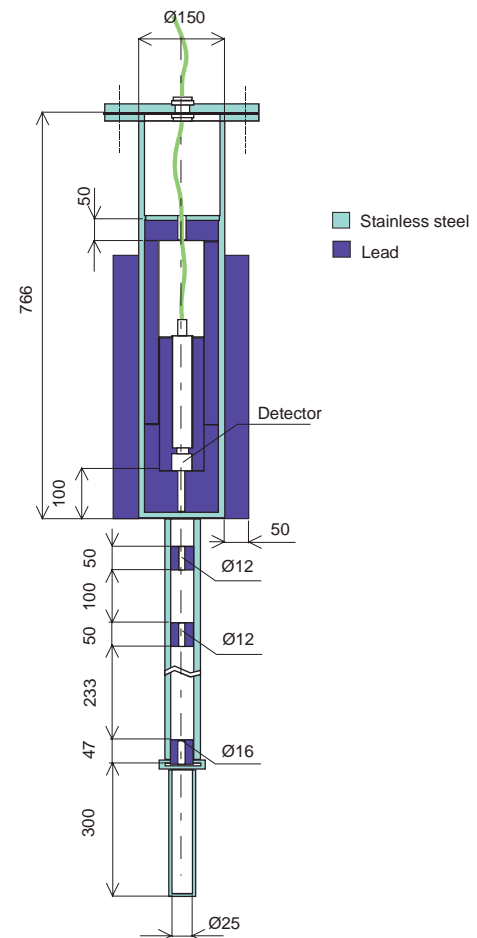
**Figure 6.** The SFAT device used at the ZNPP.

Two spectra of low burnup ($BU=12.7$ GWd/t) long-cooled assemblies measured at the ZNPP in the tight storage lattice are presented in Figure 7. Both assemblies gave a clear verification signal. The assembly #0260 was measured for 10 minutes whereas a measurement of 5 minutes was sufficient for verifying the assembly #0256. Figure 8 displays another case of low burnup long-cooled assembly #0227 together with a spectrum taken between high burnup assemblies in a tight lattice. Although the overall count rate is three times higher in the measurement taken between high burnup assemblies, no peaks are seen in this measurement. This proves that the vision of direct radiation from adjacent assemblies is sufficiently prevented in the geometry used at the ZNPP. From Table I one can see that all assemblies except one in the closed bottle were successfully verified in this campaign.

6.3 Campaign at Rovno NPP in 2001

A CZT detector of 1500 mm^3 was tested with an IAEA standard SFAT device for the first time at the Rovno NPP. It was concluded that a long collimator geometry, a total pipe length of 2.7 m, together with a 1500 mm^3 CZT detector should be applicable for verification of spent VVER-1000 assemblies, even those with low burnup and long

cooling time. The interference of adjacent assemblies was found to be not noticeable in the tight storage lattice. The shielding was found to be insufficient for the large CZT detector. Also the positioning of the IAEA standard SFAT device was found to be cumbersome and to require improvements.

6.4 Campaign at South Ukrainian NPP in 2001

The last campaign took place in 2001 in the South Ukrainian NPP. In this campaign an IAEA standard SFAT device was used with a 1500 mm^3 CZT detector. The detector shield was reinforced by changing the original shield material from lead into tungsten and adding a lead collimator, 100 mm in length and 40 mm in diameter, in front of the detector shield, see Figure 9. A three-pipe collimator of the IAEA standard SFAT, 2.7 m in total length, was used.

As the tubes of the SUNPP refuelling machine can be lifted independently, a simpler way was chosen to attach the SFAT device in the mast. A special interface was produced, which imitates the top of the assembly, where the IAEA standard SFAT was attached to, see Figure 10. This imitated fuel top was attached to the refuelling machine using the normal fuel grapple. The position accu-

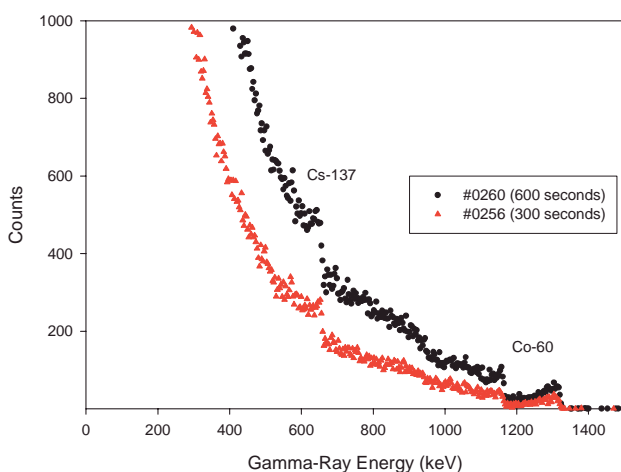

Figure 7. Spectra of two low burnup long cooled ($BU=12.7$ GWd/t, $CT=14$ years) assemblies measured at ZNPP. Assembly #0256 gave a clear verification with a measurement of 300 s, whereas assembly #0260 required 600 s of measurement time.

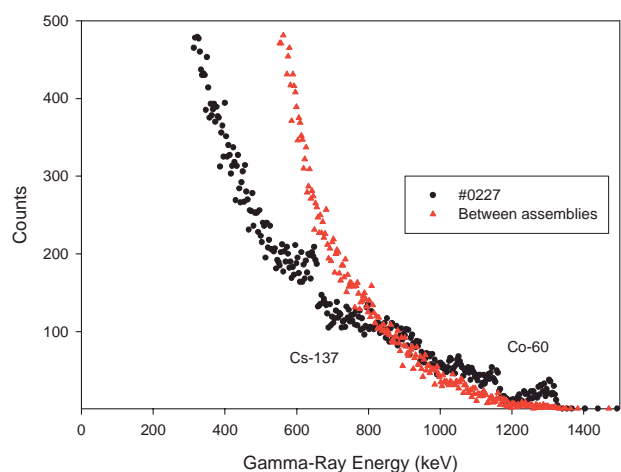

Figure 8. A low burnup ($BU=13.2$ GWd/t, $CT=14$ years) assembly and a spectrum measured between high burnup assemblies in a tight lattice of ZNPP. Measurement time 300 s.

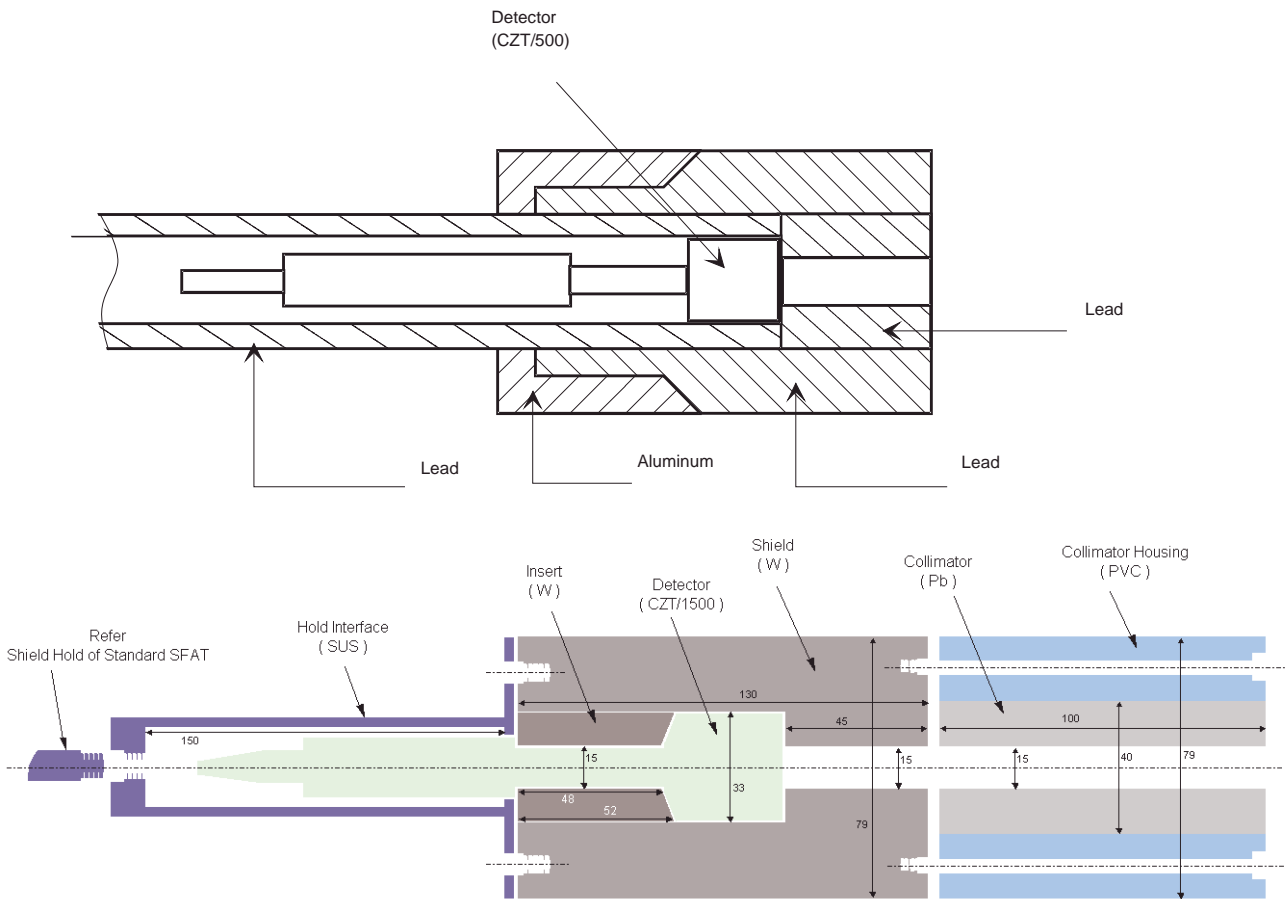

Figure 9. Enhancement of the detector shielding of the IAEA standard SFAT. Above: Shielding of standard SFAT. Below: Enhanced shielding used at SUNPP for CZT-1500 detector.

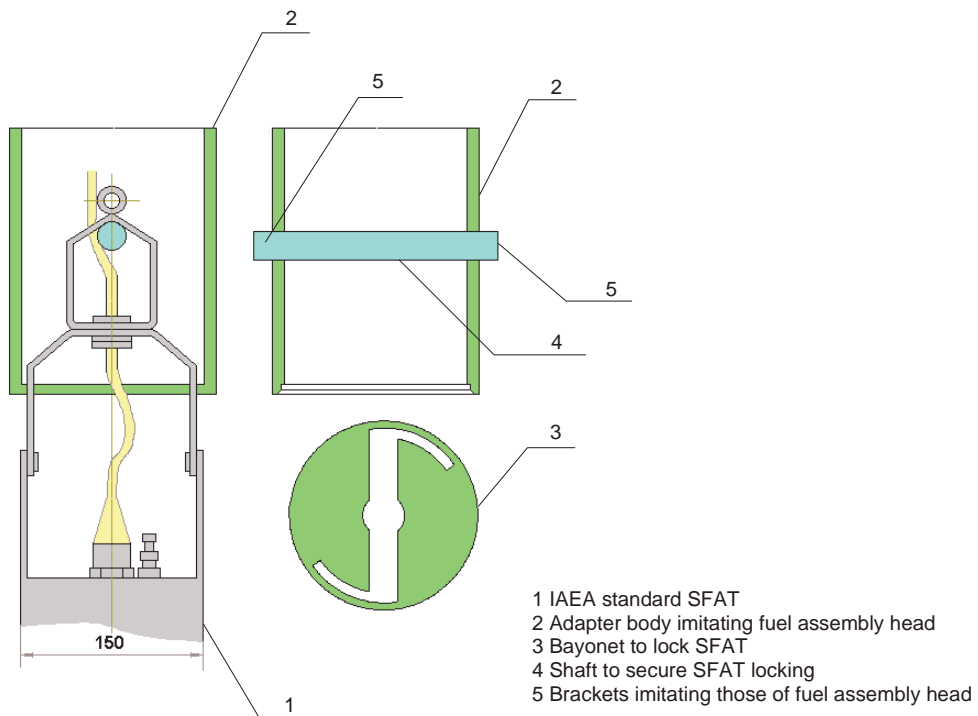

Figure 10. Refuelling machine adapter to the IAEA standard SFAT used at the SUNPP.

Table II. List of assemblies measured at the SUNPP campaign. Filename refers to the storage position in the fuel pond.

No	Assembly ID #	File name	Year of discharge	Burnup (GWd/t)	Live time (s)	Dead time (%)	Peak area	S/E	Verification (Y/N)
1	4370	B0138F	1990	12.36	300	5.5	2802	6.5	Y
2	4371	B0227F1	1990	12.36	300	20.0	2931	4.4	Y
3	4371	B0227F2	1990	12.36	300	23.0	3525	3.1	Y
4	4275	B1023F	1994	40.90	300	5.6	7633	6.6	Y
5	3737	B1021F	1993	9.55	300	1.7	624	3.8	Y
6	6836	B1336F	1995	8.90	300	12.0	3211	5.7	Y
7	4372	B0445F	1990	12.36	300	2.8	1945	6.0	Y
8	3372	B1045F	1994	48.38	60	7.5	1804	5.4	Y
9	3364	B1043F	1994	48.45	60	9.6	1740	5.7	Y
10	3362	B1041F	1994	48.45	60	10.0	1875	6.2	Y
11	3363	B1039F	1994	48.48	60	7.8	1869	4.1	Y
12	4918	B1037F	1994	40.93	60	8.9	869	3.7	Y
13	3373	B1035F	1994	48.57	60	9.0	1803	4.3	Y
14	4916	B1033F	1994	40.86	60	9.0	1152	4.4	Y
15	3361	B1031F	1994	48.49	60	7.8	1415	4.1	Y
16	4279	B1029F	1994	40.93	60	7.0	1306	4.8	Y
17	4280	B1027F	1994	40.94	60	6.5	907	3.6	Y
18	4276	B1025F	1994	40.95	60	6.8	1007	3.2	Y
19	4275	B1023FS	1994	40.90	60	5.6	1473	5.9	Y
20	3737	B1021FS	1993	9.55	60	1.3	453	2.6	Y

racy is equal both in SUNPP and in ZNPP.

Table II lists the fuel assemblies measured at the SUNPP. A total number of seventeen assemblies were measured. Three assemblies were meas-

ured twice, one #4371, the most difficult one, because of a difficulty to obtain a clear ^{137}Cs peak. Two assemblies #3737 and #4275 were measured using a 5 minutes' measurement and a short 60

seconds' measurement.

Figure 11 shows a presumably difficult case for verification, where a long cooled low burnup (ID #4370, BU=12 GWd/t, CT=11 years) assembly is stored next to four short cooled high burnup assemblies (two of BU=40 GWd/t, CT=0.5 years, two of BU=44 MWd/t, CT=1.5 years). The dead time of the measurement was 5.5%. A clear peak of ^{137}Cs is seen, and the corresponding background measurement taken between the target assembly and a neighbour shows that no nearest-neighbour contamination exists. All background measurements taken between each target and its neighbouring assembly confirm this conclusion.

The most difficult case found in the pond, assembly #4371, had six nearest-neighbours, five of them discharged during the last reloading out-

age and having a cooling time of about 0.5 a. The sixth neighbour had a cooling time of 1.5 a. The burnup of the neighbours was 34–48 GWd/t. The dead time due to extremely active neighbours was 20–23%. The two spectra shown in Figure 12 were taken from two positions above the assembly opposite to the centre axis. Although hardly visible by an eye, the SfatW95 peak analysis software revealed a significant ^{137}Cs peak. Anyway, should a case like that shown in Figure 12 occur in an inspection, it would always be possible to reverify in a later inspection.

This last test confirms that all spent fuel assemblies stored in the storage ponds of VVER-1000 reactors can be verified with a SFAT device except for those enclosed in hermetic bottles.

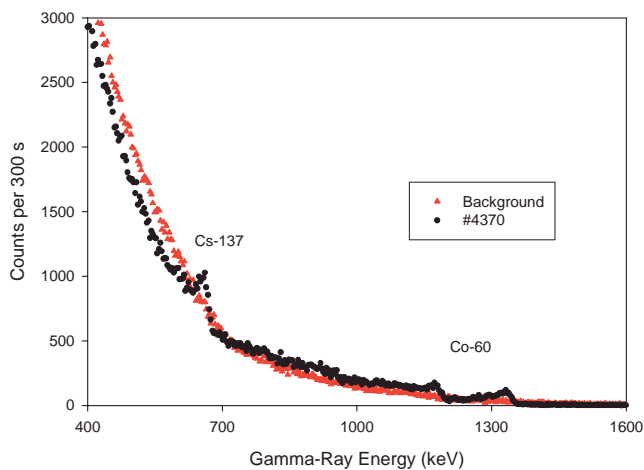

Figure 11. Verification of an assembly #4370 at SUNPP. Background spectrum was taken just next to the assembly showing no indication of the full-energy peaks.

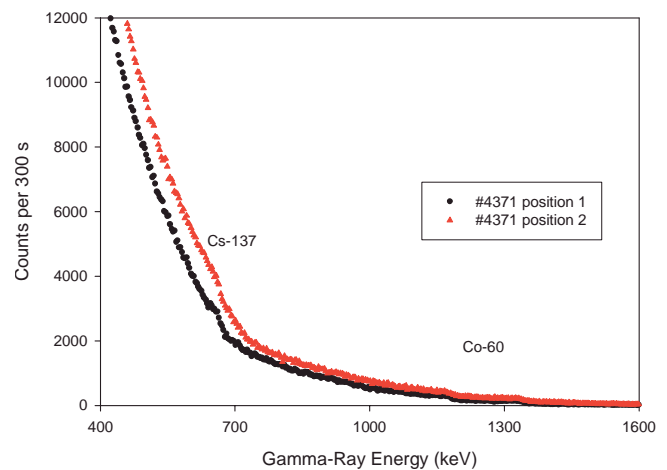

Figure 12. The most difficult case of verification at SUNPP. See explanation in the text.

7 Summary

The results obtained in the ZNPP and SUNPP campaign confirm that all VVER-1000 assemblies stored in the racks of the fuel ponds can be verified with a SFAT device attached to the refuelling machine. In the ZNPP campaigns a heavily shielded SFAT device was used consisting of a short collimator and a 500 mm³ CZT detector, see figure 6, whereas in the SUNPP campaign the device consisted of an IAEA standard SFAT body equipped with enhanced shielding and a 1500 mm³ CZT detector using the long collimator pipe geometry.

A facility-specific adapter is needed to attach a SFAT device into the refuelling machine for each facility. Such an adapter already exists at two Ukrainian facilities, South Ukrainian and Zaporozhye NPPs, and a readiness of the use of a SFAT in safeguards inspections has been attained in those two NPPs comprising nine out of the eleven

Ukrainian VVER-1000 units.

A measurement time of 60 seconds is sufficient for a positive verification in most of the cases. In extreme cases, if a low burnup long cooled assembly is stored next to recently discharged high burnup assemblies the measurement time may have to be extended up to 20 minutes. On the other hand, the activity of recently discharged assemblies decreases quite rapidly during their first years of cooling. Should the verification fail for this reason, it will always be possible to obtain a positive verification after an additional cooling period, e.g. one year,

The present design allows the use of all IAEA standard gamma spectrometry hardware and software as it is used in the IAEA standard SFAT device. This ensures that the user requirements, as presented in sec. 4, are automatically fulfilled as they are in the IAEA standard SFAT device.

Acknowledgements

The authors wish to thank the personnel of the Ukrainian NPPs for smooth and fruitful collaboration throughout this task.

References

1. SFAT Attribute Verification of LWR Spent Fuel. Standard Procedure SG-NDA-33. International Atomic Energy Agency, Vienna, 1991.
2. Nikkinen, M., Tiitta, A., Iievlev, S., Dvoeglazov, A. and Lopatin, S. Specification of a VVER-1000 SFAT Device Prototype. Report STUK-YTO-TR 155. Radiation and Nuclear Safety Authority, Helsinki, 1999.
3. Tiitta, A., Dvoeglazov, A. M., Iievlev, S. M., Tarvainen, M. and Nikkinen, M. VVER-1000 SFAT – Specification of an Industrial Prototype. Report STUK-YTO-TR 161. Radiation and Nuclear Safety Authority, Helsinki, 2000.
4. Dvoeglazov, A. M., Iievlev, S. M., Tarvainen, M., Tiitta, A., Popescu, D. and Dell, D. G. Optimisation of the measurement geometry of SFAT device for Ukrainian VVER-1000 facilities. ES-ARDA Symposium on Safeguards and Nuclear Material Management in Bruges, Belgium, 8–10 May 2001.
5. Bytchkov, V., Lee, Y. G., Goulo, V., Hosoya, M., Popescu, D., Iievlev, S. M., Dvoeglazov, A. M., Tiitta, A., Tarvainen, M. Implementation of a Modified Spent Fuel Attribute Tester for WWER-1000 in Ukraine. 43rd INMM Annual Meeting, June 23–27, 2002.
6. SFAT Attribute Measurement of Spent Fuel. Reference Manual SG-RM-36. International Atomic Energy Agency, Vienna, 2000.
7. Tarvainen, M., Paakkunainen, M., Tiitta, A., Sarparanta, K. BWR SFAT, gross-defect verification of spent BWR fuel. Report STUK-YTO-TR 72. Radiation and Nuclear Safety Authority, Helsinki, 1994.